

Ultra-Low Power CO₂ Sensor

DESCRIPTION

The CozIR®-Blink is an ultra-low power NDIR CO₂ sensor using state-of-the-art solid-state LED optical technology. The low power LEDs are manufactured in-house, giving GSS complete control of the CO₂ sensor signal chain.

The CozIR®-Blink uniquely allows users to reduce power consumption of the CO₂ measurement to unprecedented levels.

The sensor is designed to be power cycled, where the sensor is only powered-up for the duration of the measurement, and then powered down again to save power for battery powered or wireless interface applications.

The CozIR®-Blink also features a built-in auto-zero function that maintains CO₂ measurement accuracy over the lifetime of the product.

FEATURES

- Ultra-low power CO₂ sensor (60uW per reading, 60s, nPulse = 1)
- 30ppm typical measurement accuracy
- Solid state NDIR LED optical technology
- UART or I²C control and data interface
- Designed for power-cycling
- Built-in auto-zeroing

APPLICATIONS

- Air Quality and HVAC
- Building management systems (BMS)
- Demand-Controlled Ventilation (DCV) systems
- IoT and Smart Technology wireless equipment
- Indoor Air Quality (IAQ) equipment

BLOCK DIAGRAM

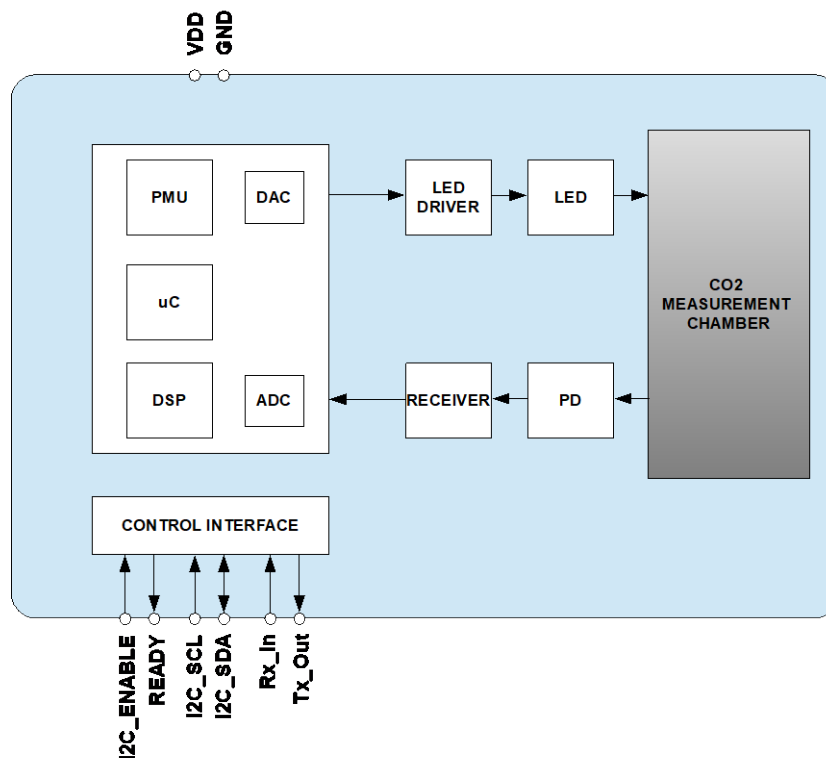

Ultra-Low Power CO₂ Sensor

TABLE OF CONTENTS

DESCRIPTION.....	1
FEATURES.....	1
APPLICATIONS.....	1
BLOCK DIAGRAM.....	1
ORDERING INFORMATION.....	4
PACKAGE DRAWING – WITH PINS.....	5
PIN-OUT DESCRIPTION – WITH LEADS.....	6
SENSOR CONNECTION DIAGRAM – WITH PINS.....	6
PACKAGE DRAWING – NO PINS.....	7
PIN-OUT DESCRIPTION – NO PINS.....	8
SENSOR CONNECTION DIAGRAM – NO PINS.....	8
RECOMMENDED EXTERNAL COMPONENTS – POWER CONTROL CIRCUIT.....	9
ABSOLUTE MAXIMUM RATINGS.....	10
RECOMMENDED OPERATING CONDITIONS.....	10
PERFORMANCE CHARACTERISTICS.....	11
ELECTRICAL CHARACTERISTICS.....	12
POWER CONSUMPTION.....	13
METHOD OF OPERATION.....	15
DATA READY.....	15
MEASUREMENT CYCLE.....	16
DIGITAL FILTER SETTING.....	17
ZERO POINT SETTING.....	18
ZERO IN A KNOWN GAS CONCENTRATION.....	18
ZERO IN NITROGEN.....	18
ZERO IN FRESH AIR.....	18
AUTO-ZERO FUNCTION.....	19
AUTO-ZERO LEVEL.....	20
AUTO-ZERO INTERVALS.....	20
ALTITUDE COMPENSATION.....	21
SELECTION OF CONTROL INTERFACE.....	22
CONTROL INTERFACE TIMING - I ² C MODE.....	22
I ² C INTERFACE MODE.....	23
WRITING TO AN I ² C REGISTER.....	24
READING FROM AN I ² C REGISTER.....	24
I ² C REGISTER MAP SUMMARY.....	25
CO ₂ LEVEL MEASUREMENT VALUE.....	26
ZERO SETTING CONTROL.....	26
ZERO IN FRESH AIR.....	26
ZERO IN A KNOWN GAS CONCENTRATION.....	26
AUTO-ZERO CYCLES.....	27
SERIAL NUMBER.....	27
nPULSE.....	27
AUTO-ZERO CONTROL.....	27



Ultra-Low Power CO₂ Sensor

ALTITUDE COMPENSATION.....	27
CONNECTION DIAGRAM FOR I ² C INTERFACE.....	28
UART INTERFACE MODE	29
CONTROL INTERFACE TIMING - UART MODE	29
UART COMMAND PROTOCOL.....	29
UART OPERATION	29
UART INTERFACE SUMMARY	30
CO ₂ LEVEL MEASUREMENT VALUE - Z INFORMATION (0x5A)	31
CO ₂ MEASUREMENT Z SCALING FACTOR – UART MODE.....	32
‘ ’ COMMAND (0x2E).....	32
nPULSE SETTING – UART MODE.....	32
A COMMAND (0x41)	32
a COMMAND (0x61).....	32
ZERO POINT SETTING COMMANDS – UART MODE	33
G COMMAND (0x47)	34
U COMMAND (0x55).....	34
u COMMAND (0x75)	34
X COMMAND (0x58)	34
P COMMAND - CO ₂ Level for Auto-Zero	35
P COMMAND – CO ₂ Level for Zero-Point Setting.....	35
ALTITUDE PRESSURE COMPENSATION	36
[COMMAND (0x5B)	36
] COMMAND (0x5D).....	36
AUTO-ZERO INTERVAL – UART MODE	37
@ COMMAND (0x40).....	37
SERIAL NUMBER AND FIRMWARE VERSION – UART MODE.....	37
Y COMMAND (0x59).....	38
CONNECTION DIAGRAM FOR UART INTERFACE	39
IMPORTANT NOTICE	40
ADDRESS	40

Ultra-Low Power CO₂ Sensor

ORDERING INFORMATION

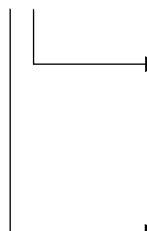
COZIR-BLINK-X-X

	X	Measurement Range
	2000	2000ppm
	5000	5000ppm
	1	10,000ppm (1%)
	X	Package Option
	Blank	With pins
	N	No pins

Notes:

1. Sensors are shipped individually or in trays
2. Tray quantity = 50

See separate data sheet for CozIR®-Blink evaluation kit options.

Ultra-Low Power CO₂ Sensor

PACKAGE DRAWING – WITH PINS

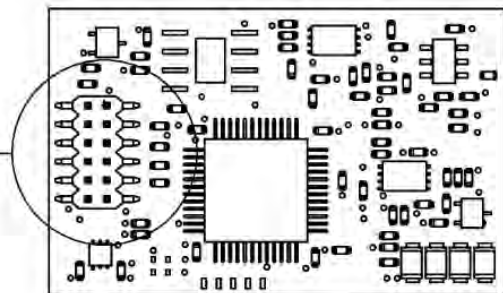
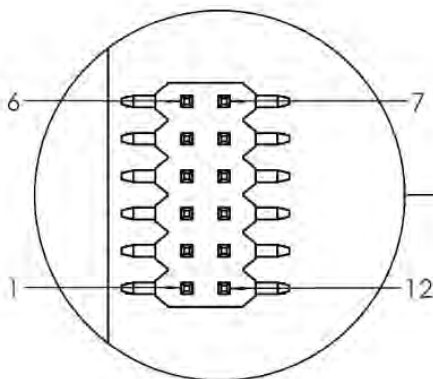
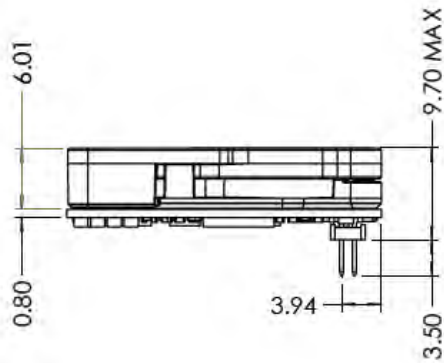
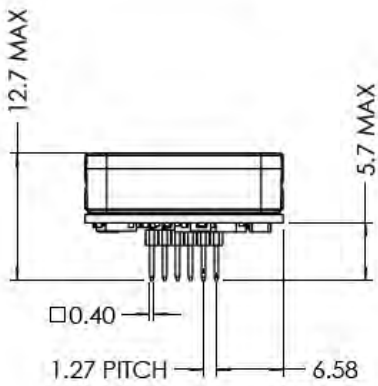
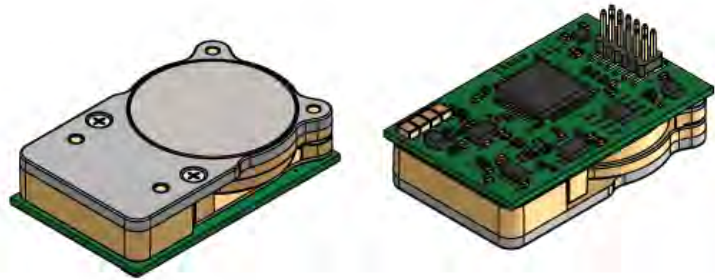
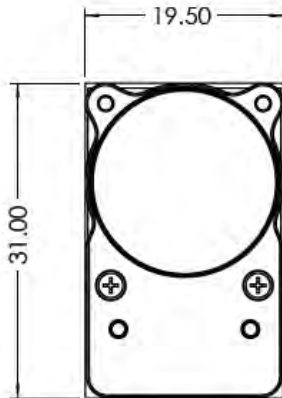

Bottom View

Weight = 5g

Ultra-Low Power CO₂ Sensor

PIN-OUT DESCRIPTION – WITH LEADS

PIN	NAME	TYPE	DESCRIPTION
1	GND	Supply	Sensor ground
2	VDD	Supply	Sensor supply voltage
3	Rx_In	Digital Input	UART Receive Input
4	Tx_Out	Digital Output	UART Transmit Output
5	NC	Unused	Do not connect
6	READY	Digital Output	Data ready pin. Pulsed high when data ready
7	NC	Unused	Do not connect
8	NC	Unused	Do not connect
9	NC	Unused	Do not connect
10	I2C_ENABLE	Digital Input	Set low for I ² C interface mode. Leave floating to select UART interface mode. Pin status detected at power on.
11	I2C_SCL	Digital Input	I ² C serial clock input. Open drain, external 4.7kΩ resistor pulled high to VDD required
12	I2C_SDA	Digital Input/Output	I ² C serial data input/output. Open drain, external 4.7kΩ resistor pulled high to VDD required

SENSOR CONNECTION DIAGRAM – WITH PINS

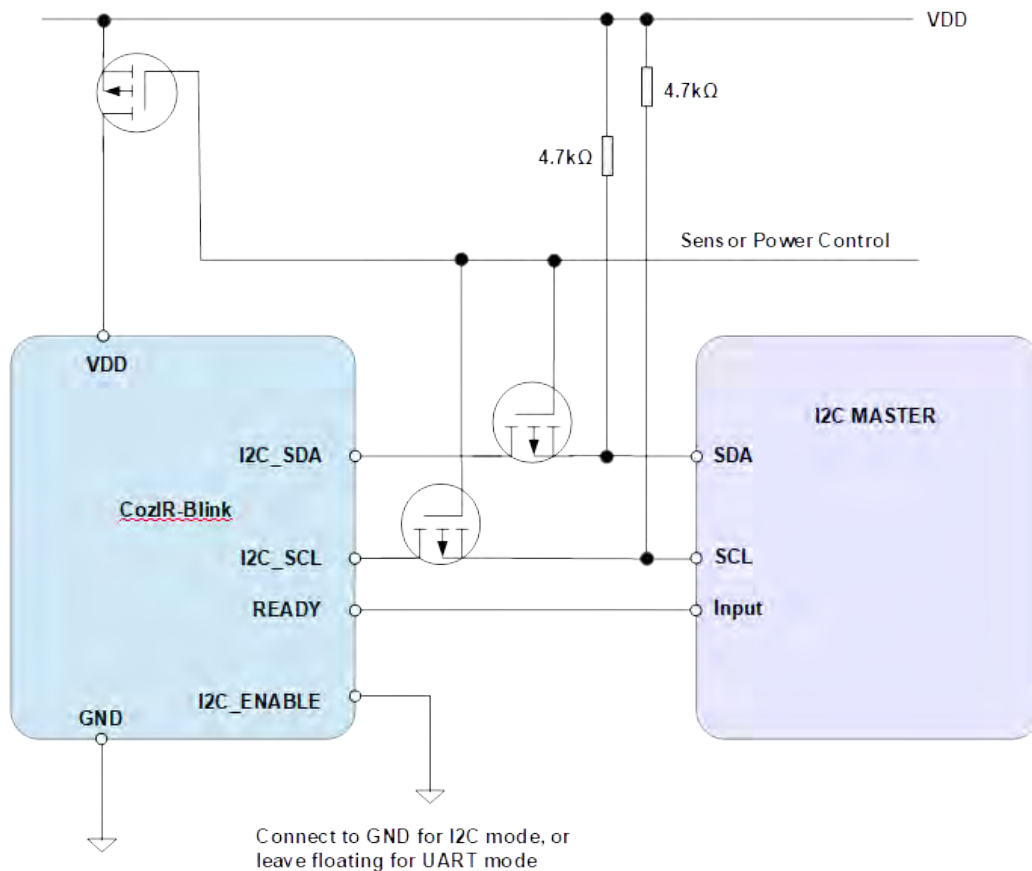

Ultra-Low Power CO₂ Sensor

PACKAGE DRAWING – NO PINS

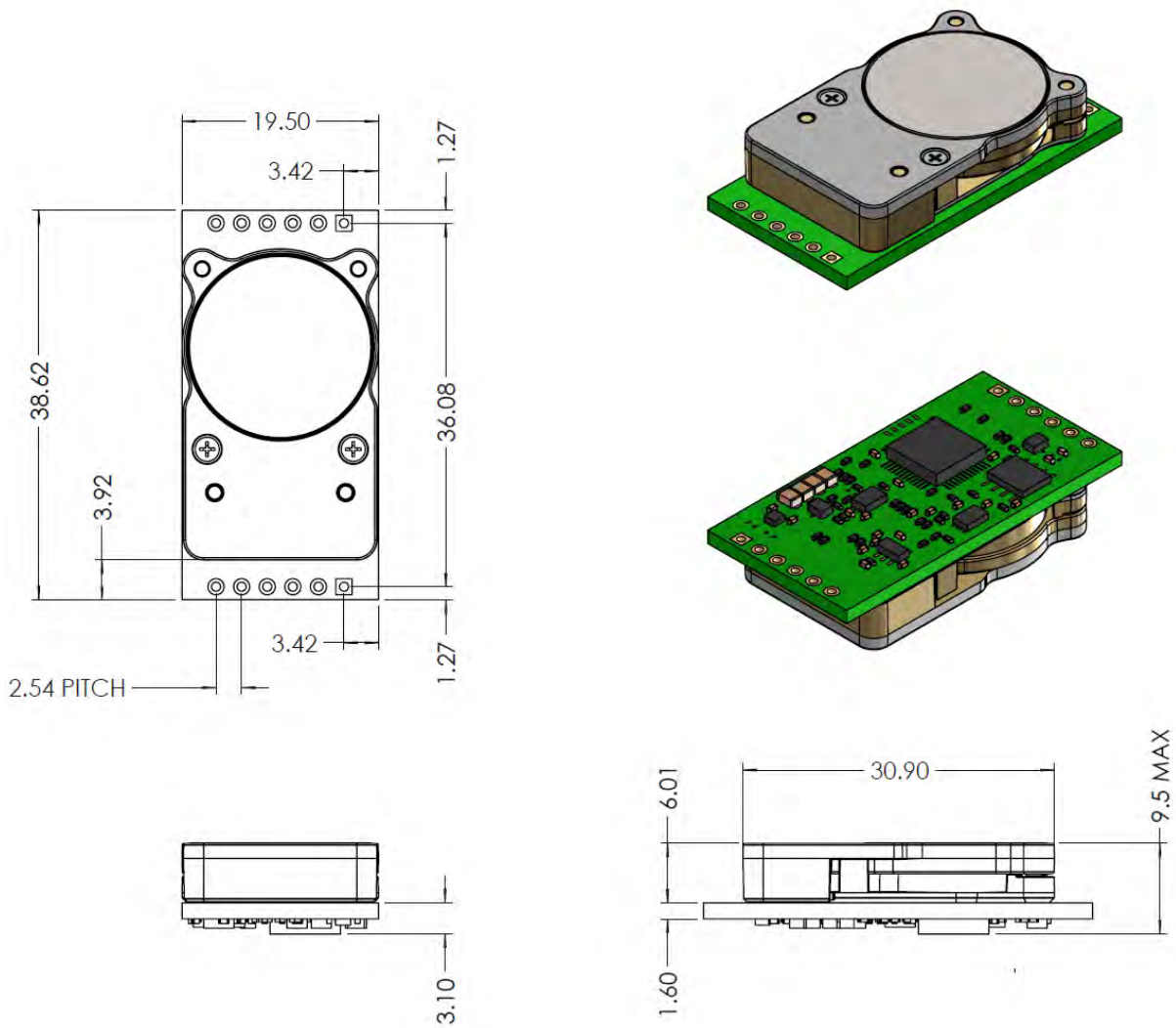

Weight = 4.9g

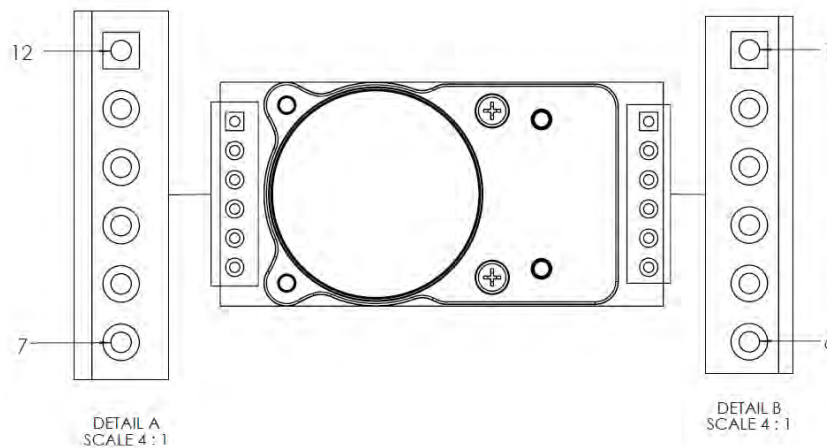

Ultra-Low Power CO₂ Sensor

Top View

PIN-OUT DESCRIPTION – NO PINS

PIN	NAME	TYPE	DESCRIPTION
1	GND	Supply	Sensor ground
2	VDD	Supply	Sensor supply voltage
3	NC	Unused	Do not connect (For internal use only)
4	VDD1	Supply	Sensor supply voltage
5	NC	Unused	Do not connect
6	READY	Digital Output	Data ready pin. Pulsed high when data ready
7	NC	Unused	Do not connect
8	I2C_ENABLE	Digital Input	Set low for I ² C interface mode. Leave floating to select UART interface mode. Pin status detected at power on.
9	I2C_SCL	Digital Input	I ² C serial clock input. Open drain, external 4.7kΩ resistor pulled high to VDD required
10	I2C_SDA	Digital Input/Output	I ² C serial data input/output. Open drain, external 4.7kΩ resistor pulled high to VDD required
11	Tx_Out	Digital Output	UART Transmit Output
12	Rx_In	Digital Input	UART Receive Input

SENSOR CONNECTION DIAGRAM – NO PINS

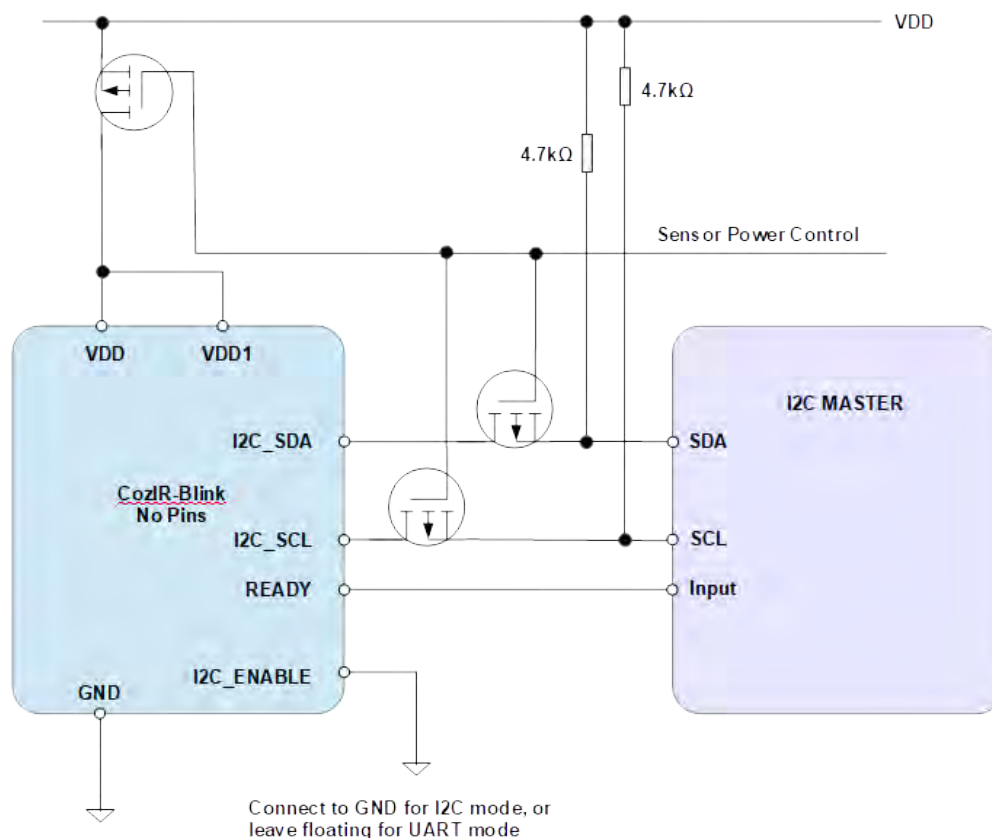

Ultra-Low Power CO₂ Sensor

RECOMMENDED EXTERNAL COMPONENTS – POWER CONTROL CIRCUIT

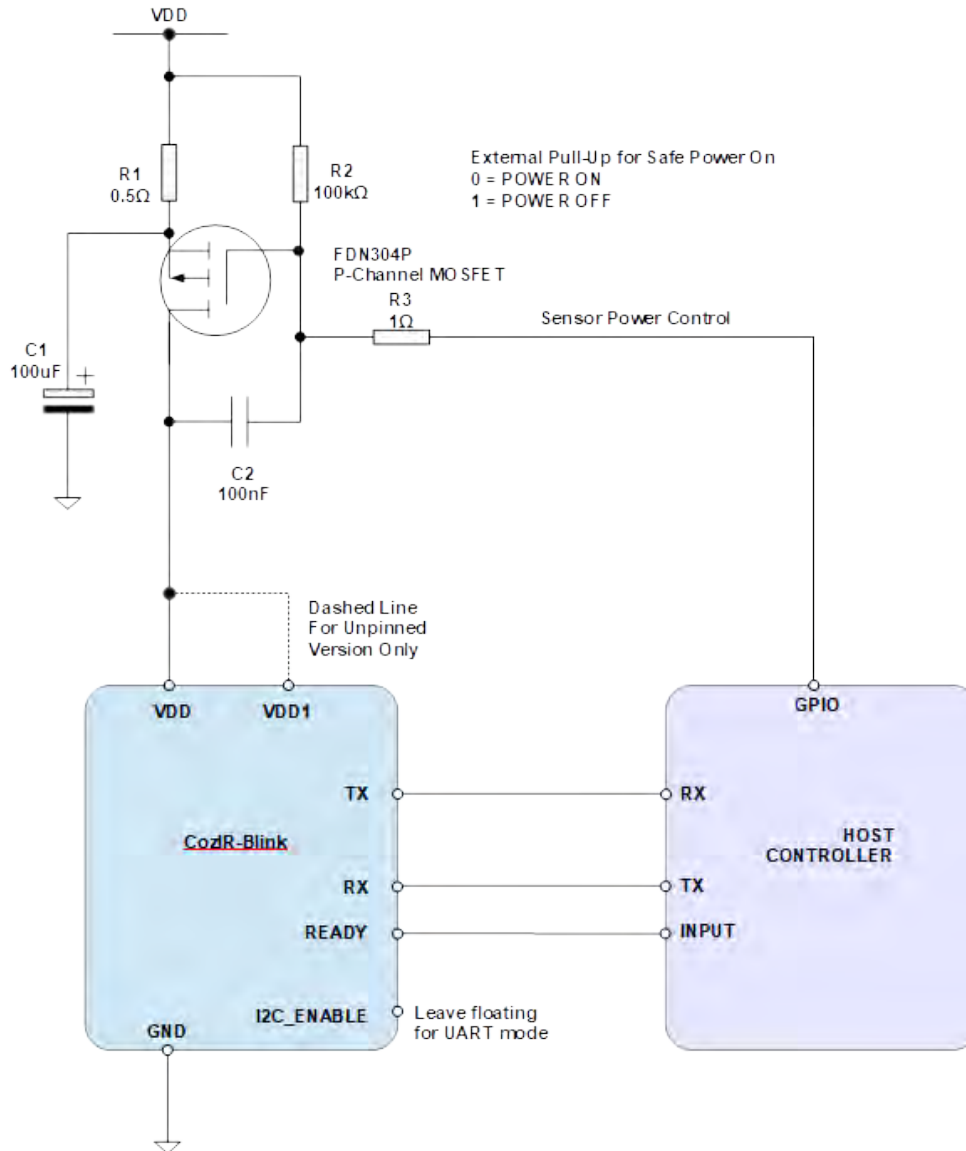

Component description

- R1 – Inrush current limit
- R2 – Pull up, ensure safe power on
- R3 – Gate protection
- C1 – Ensure VDD stability
- C2 – Improved switching control

Notes

1. C2 slows the turn on to help reduce transient impact on the VDD
2. The 100µF cap C1 charged via R1 provides the inrush current, whilst R1 also protects VDD from seeing any dips from transient load
3. Host GPIO is best setup as Open Drain drive, helps with voltage difference between supply rails
4. Host power supply ideally should not be lower than VDD by more than 0.3V to ensure compliance with FET V_{gs}

Ultra-Low Power CO₂ Sensor

ABSOLUTE MAXIMUM RATINGS

Absolute Maximum Ratings are stress ratings only. Permanent damage to the CozIR®-Blink may be caused by continuously operating at or beyond these limits. The CozIR®-Blink functional operating limits and guaranteed performance specifications are given at the test conditions specified.



ESD Sensitive Device. This sensor uses ESD sensitive components. It is therefore generically susceptible to damage from excessive static voltages. Proper ESD precautions must be taken during handling and storage of this device.

CONDITION	MIN	MAX
Supply Voltages	-0.3V	+6.0V
Voltage Range Digital Inputs	GND -0.3V	5V
Operating Temperature Range (T _a)	0°C	+50°C
Storage Temperature Range	-40°C	+70°C
Humidity Range (RH), non-condensing	0	95%
Operating Ambient Pressure Range	500mbar	2bar

RECOMMENDED OPERATING CONDITIONS

PARAMETER	SYMBOL	MIN	TYP	MAX	UNIT
Supply	VDD/VDD1	3.25	3.3	5.5	V
Ground	GND		0		V

Ultra-Low Power CO₂ Sensor

PERFORMANCE CHARACTERISTICS
Test Conditions Unless Otherwise Specified

VDD/VDD1 = 3.3V, GND = 0V. CO₂ = 450ppm, RH = 0% non-condensing, T= 25°C, Pressure = 1013mbar, nPulse = 16

PARAMETER	SYMBOL	TEST CONDITIONS	MIN	TYP	MAX	UNIT
CO ₂ measurement range			0		2,000	ppm
			0		5,000	ppm
			0		10,000	ppm
Accuracy		@25°C		±(30 +3%rdg)	±(45 +3%rdg)	ppm
		0°C to +50°C, after auto-zero @25°C		±(30 +3%rdg +0.14%rdg per °C)		ppm
CO ₂ RMS Noise		16 pulses per reading.		6		ppm
Time to Valid Measurement After Power-On		Dependent on number of pulses per reading	0.5	3.5		secs
Response Time		From 0ppm to T ₅₀ (half full-scale), default settings, limited by diffusion through membrane window		30		secs
Repeatability				±(30 +3%rdg)		ppm
Pressure Dependence ^{1,2,3}		Per mbar deviation from 1013mbar, 950-1050mbar		0.14		%
Current Consumption		Peak current when sampling, 16 pulses per reading		15		mA
		Peak at turn-on		40		mA
		SLEEP Mode		0.01		mA
		OFF		0		mA

Note

- CO₂ measurement error based on changes to barometric pressure from nominal 1013mbar
- Corrected value (Z) valid only for <1% CO₂ gas concentrations and specified barometric pressure range

$$3. \quad Z_{(corrected)} = Z_{(actual\ reading)} + Z_{(actual\ reading)} * \frac{(1013 - Actual\ Pressure) * 0.14}{100}$$

Ultra-Low Power CO₂ Sensor

ELECTRICAL CHARACTERISTICS

PARAMETER	SYMBOL	TEST CONDITIONS	MIN	TYP	MAX	UNIT
Digital Input/Output						
Input HIGH Level			1.8			V
Input LOW Level					1.0	V
Output HIGH Level		I _{OH} = +1mA	2.6			V
Output LOW Level		I _{OL} = -1mA			0.4	V

Ultra-Low Power CO₂ Sensor

POWER CONSUMPTION

Test Conditions Unless Otherwise Specified

VDD/VDD1 = 3.3V, GND = 0V. CO₂ = 450ppm, RH = 0% non-condensing, T= 25°C, Pressure = 1013mbar

SETTING	SYMBOL	TEST CONDITIONS	VDD		Total Power
			V	I (mA)	mW
OFF		No power applied		0	0
Active, SLEEP mode, no measurement			3.3	0.01	0.03

The energy per reading is approximately 25mJ using default settings. Power consumption is strongly dependent on digital filter settings (# of pulses) and the measurement period.

$$Power (\mu W) = \frac{1.5625 * \text{number of pulses per reading}}{\text{Measurement period in Seconds}} * 1000$$

In a typical application where the user might want to take a reading every 300s, the power requirement is ~10uW per reading. Power consumption can be lowered even further by increasing the measurement interval.

Current consumption varies depending on digital filter settings (# of pulses). A typical current consumption profile is shown below.

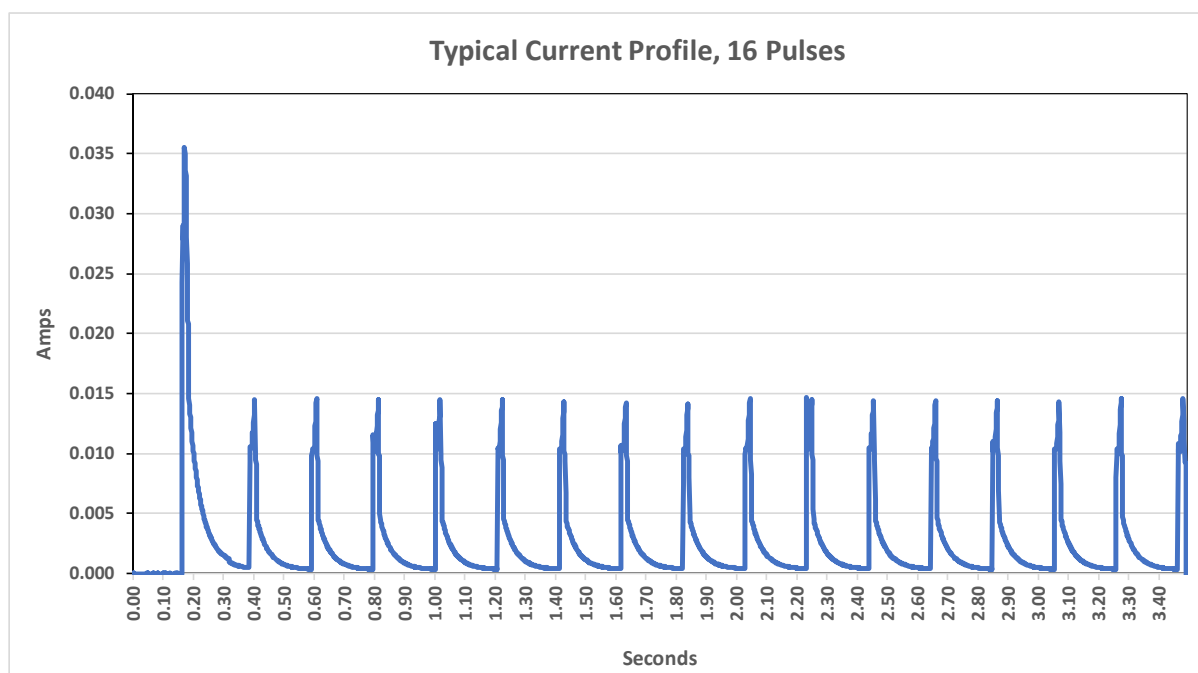

Ultra-Low Power CO₂ Sensor

The graph below shows the trade-off between nPulse, the measurement period and the impact on average power consumption.

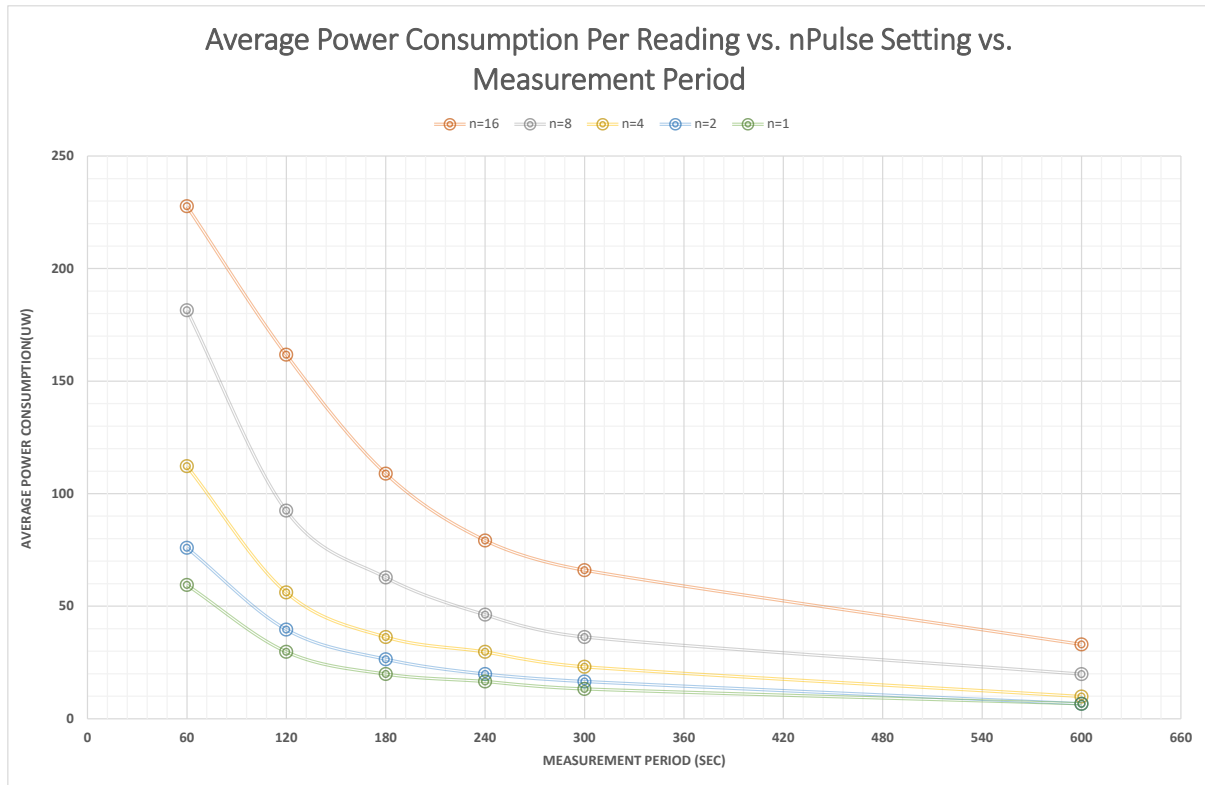

Ultra-Low Power CO₂ Sensor

METHOD OF OPERATION

The CozIR®-Blink is designed for ultra-low power applications where power is often at a premium. CozIR®-Blink is designed to be power cycled. When the sensor is switched on, a measurement is automatically initiated. Data can be read out once the READY pin is pulsed high. The sensor can then be subsequently switched off, saving power.

DATA READY

After power is applied to the CozIR®-Blink, the sensor will automatically start to take CO₂ measurements using the configured settings. Once the READY flag has been pulsed high, the sensor will respond to requests for CO₂ data. The control interface is available approximately 14ms after the falling edge of a valid READY pulse.

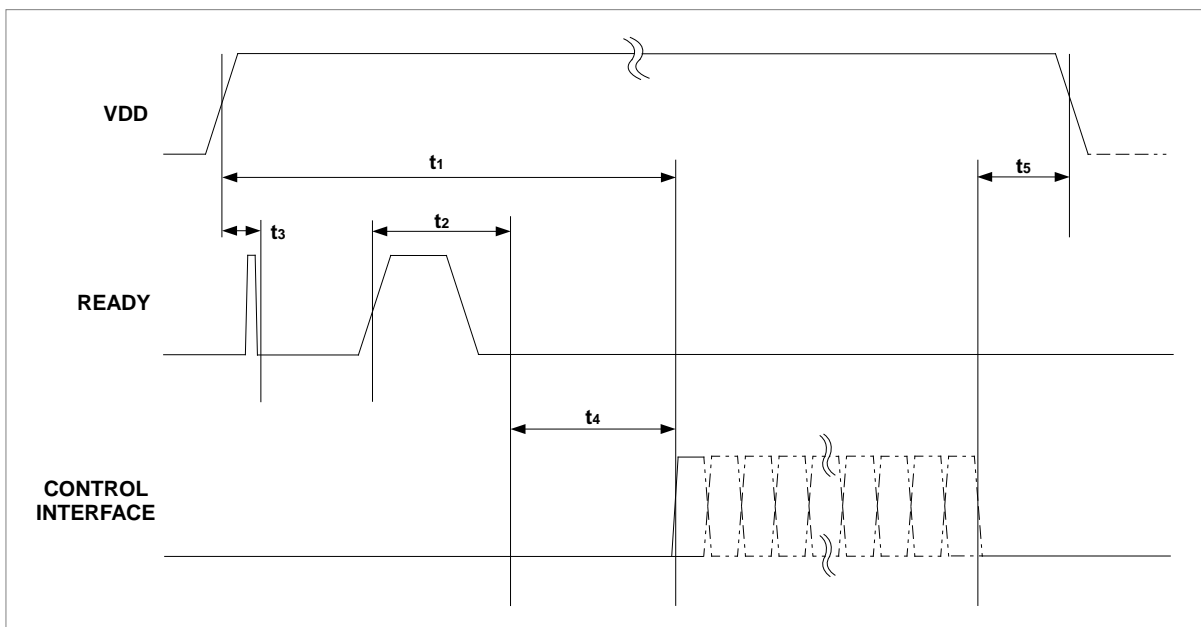

PARAMETER	SYMBOL	MIN	TYP	MAX	UNIT
READY Data Valid from Power On	t ₁	0.5	3.5		s
READY High Pulse-Width	t ₂		1.0		ms
READY Low from Power On	t ₃			100	ms
Control Interface Setup Time	t ₄	14			ms
Control Interface Active to Safe Shutdown Time ¹	t ₅	228	5.8		ms

Notes

1. Time needed for the sensor to safely shut down after the user has written to or read from memory.

Ultra-Low Power CO₂ Sensor

MEASUREMENT CYCLE

The measurement cycle is the same in either UART or I²C connection mode but the method of obtaining the CO₂ value is different.

- Apply power to the Sensor
- The sensor will automatically start taking measurements. The sensor takes a measurement using the configured number of pulses (*npulse*). The default setting is 16
- The measurement time is approximately 200ms + (200ms x *npulse*)
- The typical measurement time using the default setting *npulse* of 16 is 3400ms
- The data READY flag is set low within 100ms of power on.
- When the measurement is complete, the data READY flag will be pulsed high for approximately 1.0ms with data available approximately 14ms after the falling edge of the READY flag.
- ***In UART mode, the CO₂ reading can only be read once by the user.*** The sensor will not report the CO₂ reading again after this point and a new measurement will not be taken until the sensor is power cycled. After the initial request, the sensor will respond with an invalid command if a CO₂ reading is requested again.
- In I²C mode, the user should wait for 14ms after the READY flag is pulsed high and the appropriate register can be read. In this mode, the register reading can be read repeatedly but the value will not change until the sensor is power cycled again.
- After the measurement is sent to or read by the host (depending on UART or I²C mode), the sensor will go into SLEEP mode, and will take no further measurements until the power is cycled again
- During SLEEP mode, the sensor will respond to commands, and can be re-configured but no further measurements will be taken
- If a sensor register value is changed, sufficient time must be allowed to ensure the new value is safely written to memory
- Note, if the sensor does an auto-zero, it will extend the measurement time by ~2s but is done before the READY flag is asserted high
- A new measurement cycle will only start the next time the sensor is power cycled
- The number of pulses (*npulse*) can be set and read by the user

All sensor settings are stored in non-volatile memory. The sensor should only be configured once. It should not be configured every power cycle as this consumes unnecessary power.

Ultra-Low Power CO₂ Sensor

DIGITAL FILTER SETTING

The CO₂ gas chamber is illuminated with a nominal 4.25um wavelength LED and the signal received using a photodiode. The LED output is 'pulsed' several times per measurement reading. The signal from the photodiode is processed and filtered by the sensor to remove noise and provide an accurate CO₂ reading.

The number of 'pulses' used by the sensor is a balance between CO₂ reading accuracy and power consumption. The energy required per measurement is directly proportional to the number of pulses (*npulse*).

Higher values of *npulse* will reduce noise and improve resolution. A lower value of *npulse* reduces the energy per measurement. The user should carefully consider the compromise between power consumption and resolution to determine the optimum setting of *npulse* for the application. The factory default is 16 and the maximum value is 32, and the minimum number is 1.

The value of *npulse* is stored on the sensor and can be read by the host controller. If the value of *npulse* is changed, the sensor must be zero-calibrated.

Ultra-Low Power CO₂ Sensor

ZERO POINT SETTING

In all cases, the best zero is obtained when the gas concentration is stable, and the sensor is at a stabilised temperature. Zero-point settings are not cumulative and only the latest zero-point setting is effective. For example, there is no benefit in zeroing in nitrogen, and then zeroing in a calibration gas. The sensor will store only the latest zero point regardless of what method is used. There are a several different methods available to the user to set the zero point of the sensor.

ZERO IN A KNOWN GAS CONCENTRATION

Place the sensor in a known gas concentration and allow time for the sensor temperature to stabilise, and for the gas to be fully diffused into the sensor.

Power up the sensor, wait for the READY pin to indicate measurement is complete. Write the known concentration level to the sensor, then initiate the Zero in a Known Gas zeroing method. The concentration must be in ppm.

ZERO IN NITROGEN

Place the sensor in the nitrogen gas and allow time for the sensor temperature to stabilise, and for the gas to be fully diffused into the sensor. Power up the sensor, wait for the READY pin to indicate measurement done. Initiate the Zero in Nitrogen command. The sensor is zeroed assuming a 0ppm CO₂ environment.

ZERO IN FRESH AIR

If there is no calibration gas or nitrogen available, the sensor zero point can be set in fresh air. Ambient CO₂ concentrations in fresh air are typically 400ppm. This level is programmable over a range from 0ppm to the full scale of the sensor.

Place the sensor in a fresh air environment and allow time for the sensor temperature to stabilise, and for the fresh air to be fully diffused into the sensor. Power up the sensor, wait for the READY pin to indicate measurement done.

Once the initial CO₂ measurement has been completed, the user can initiate a new Zero in Fresh Air zeroing cycle. The sensor can use the default fresh air CO₂ concentration value (400ppm), or the user can write a different fresh air value to the sensor if desired. The concentration must be in ppm.

Ultra-Low Power CO₂ Sensor

AUTO-ZERO FUNCTION

The sensor has a built-in auto-zero function. In order to function correctly, the sensor must be exposed to typical background levels (400-450ppm) at least once during the auto-zero period. For example, many buildings will drop quickly to background CO₂ levels when unoccupied overnight or at weekends. The auto-zero function uses the information gathered during these periods to re-zero. The sensor will reset the 'zero' level every time it does an auto-zero. Auto-zeroing is enabled by default.

The CozIR®-Blink keeps a record of the lowest measured CO₂ value in memory (Z_{lowest}). The sensor also keeps a record of the last CO₂ measurement. Every time the CozIR®-Blink takes a new measurement, the previous and current values are filtered to create a new value (Z_{new}).

$$Z_{new} = \frac{Z_{cur} - Z_{prev}}{2} + Z_{prev}$$

If the value of Z_{new} value is lower than the stored Z_{lowest} , Z_{lowest} is updated.

When the auto-zero function is run, the sensor will reset the fresh-air zero point using Z_{lowest} . The value the sensor uses for this fresh-air zero-point is user programmable. The sensor default value for CO₂ in fresh air is 400ppm. When the auto-zero function is run, the sensor sets the Z_{lowest} value of CO₂ of the fresh air to 400ppm. The default value can be changed by the user if needed.

Z_{lowest} is stored and all settings are retained in non-volatile memory when power is removed from the sensor.

Ultra-Low Power CO₂ Sensor

AUTO-ZERO LEVEL

The background concentration will depend on sensor location. Ambient levels are typically in the range of 400ppm - 450ppm. The factory default is set to 400ppm. The user can change the background ambient level used for auto-zeroing. The value is stored in the sensor.

AUTO-ZERO INTERVALS

The auto-zero period is based on the number of power cycles. The CozIR®-Blink records the number of power cycles since the last auto-zero event. When it reaches a pre-defined threshold, auto-zero will be triggered. The number of cycles can be configured by the user.

For example, if the sensor is programmed to take a reading once every 5 minutes, with auto-zero to be set for every 7 days, set the auto-zero threshold to 2,016 (12 times per hour x 24 hours per day x 8 days). The auto-zero routine will trigger after 2,016 power cycles.

Note, an auto-zero operation will extend the time from power-on to when valid measurements are available (defined by status of READY flag) by approximately 2s.

The sensor default is auto-zero enabled. However, auto-zero can be disabled, or auto-zero can be forced. The auto-zero counter is reset automatically if the user forces an auto-zero directly. The auto-zero counter is available to be read back by the controller.

Readings for the first 50 power cycles are not used, to ensure that data collected is sufficiently independent of the previous auto zero. The advised auto-zero minimum power cycle count is 100 for the CozIR®-Blink. The actual value set should take account of the number of measurements taken over a number of days, ideally more than 7 days.

If nPulse is set to 50, the following applies.

- The auto-zero is done before the READY pulse is asserted high.
- If auto-zero is set to 50 cycles, on the 51st power cycle, the sensor will start taking measurements to generate a reading, do the auto-zero and then assert the READY pulse.
- The new zero point will be used on the calculations for the 52nd measurement.

Ultra-Low Power CO₂ Sensor

ALTITUDE COMPENSATION

NDIR gas sensors detect the concentration of gas by measuring the degree of light absorption by the gas analyte. The degree of light absorption is then converted into a concentration reported by the sensor.

The absorption process is pressure dependent, and a change in pressure will cause a change in the reported gas concentration. As the pressure increases, the reported gas concentration also increases. As the pressure decreases, the reported concentration decreases. This effect takes place at a molecular level and is common to all NDIR gas sensors.

GSS sensors are calibrated at 1013mbar. The reading from the sensor will vary from the nominal output if the mean barometric pressure is different from the calibration setting. It is possible to configure the sensor to correct for this effect by writing the actual or reference mean barometric pressure in mbar to the sensor. This can be done as part of the initial set up process or updated at any time during use. This will apply a permanent correction to the output of the sensor, depending on the altitude setting selected.

Ultra-Low Power CO₂ Sensor

SELECTION OF CONTROL INTERFACE

The CozIR®-Blink is controlled by writing to registers through a serial control interface. The control interface can be configured as a UART or 2-wire I²C interface.

Selection of the control interface is done via the I2C_ENABLE pin. The state of the I2C_ENABLE pin is sampled at power up only. The status cannot be changed after power up. Setting the I2C_ENABLE pin low puts the CozIR®-Blink into I²C interface mode. Leaving the I2C_ENABLE pin floating puts the CozIR®-Blink into UART control interface mode.

CONTROL INTERFACE TIMING - I²C MODE

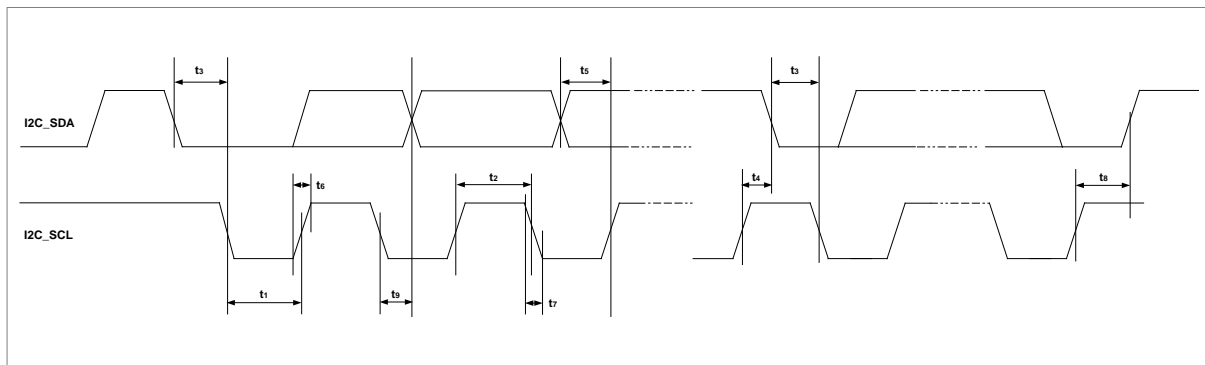

PARAMETER	SYMBOL	MIN	TYP	MAX	UNIT
I2C_SCL Frequency		0		100	kHz
I2C_SCL Low Pulse-Width	t_1	4.7			us
I2C_SCL High Pulse-Width	t_2	4.0			us
Hold Time (Start Condition)	t_3	4.0			us
Setup Time (Start Condition)	t_4	4.7			us
Data Setup Time	t_5	250			ns
I2C_SDA, I2C_SCL Rise Time	t_6			1000	ns
I2C_SDA, I2C_SCL Fall Time	t_7			300	ns
Setup Time (Stop Condition)	t_8	4.0			us
Data Hold Time	t_9	0		5.0	us
Capacitive load for each bus line	-			400	pF

Ultra-Low Power CO₂ Sensor

I²C INTERFACE MODE

The CozIR®-Blink supports software control via a 2-wire serial bus. Many devices can be controlled by the same bus, and each device has a unique 7-bit address (this is not the same as the 8-bit address of each register in the CozIR®-Blink). The CozIR®-Blink operates as a slave only device.

The controller indicates the start of data transfer with a high to low transition on I2C_SDA while I2C_SCL remains high (I²C Start condition). This indicates that a device address will follow. All devices on the 2-wire bus respond to the start condition and shift in the next eight bits on I2C_SDA (7-bit address + Read/Write bit, MSB first).

If the device address received matches the address of the CozIR-BLINK and the R/W bit is '0', indicating a write, then the CozIR®-Blink responds by pulling I2C_SDA low on the next clock pulse (ACK). If the address is not recognised or the R/W bit is '1', the CozIR®-Blink returns to the idle condition and waits for a new start condition and valid address.

The CozIR®-Blink acknowledges the correct address by pulling I2C_SDA low for one clock pulse. The master then sends the address of the register it wishes to read from or write to. Data is either read from or written to in 1 - 4 bytes, most significant byte (MSB) first.

The transfer of data is complete when there is a low to high transition on I2C_SDA while I2C_SCLK is high. After receiving a complete address and data sequence the CozIR®-Blink returns to the idle state and waits for another start condition. If a start or stop condition is detected out of sequence at any point during data transfer (i.e., I2C_SDA changes while I2C_SCL is high), the device jumps to the idle condition.

The CozIR®-Blink device address is 0x41.

Ultra-Low Power CO₂ Sensor

WRITING TO AN I²C REGISTER

The controller (Master) sends a START condition to the sensor. The sensor acknowledges the controller by setting the R/W bit low, indicating it is expecting the controller to write to a register. The controller sends the register address that it wants to write to, and then 1-4 data bytes. Once the controller has completed the operation, it sends the STOP condition.

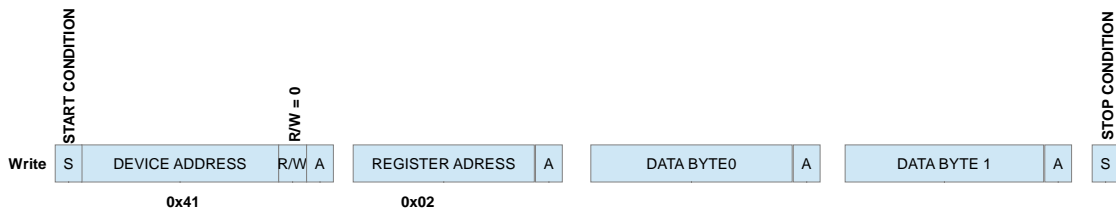

READING FROM AN I²C REGISTER

The controller (Master) sends a START condition to the sensor. The sensor acknowledges the controller by setting the R/W bit high, indicating it is expecting the controller to read from a register. The controller (Master) must send another START condition to the sensor and the sensor address with R/W bit set to read. Then read out 1-4 data bytes. Once the controller has completed the operation, it sends the STOP condition.

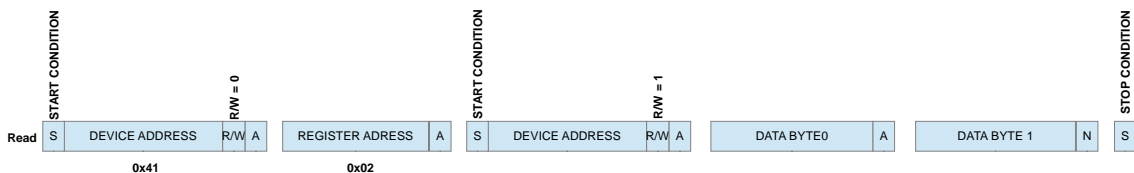

The CozIR®-Blink supports clock stretching. In an I²C communication, the master device determines the clock speed. The I²C bus provides an explicit clock signal running at a pre-defined rate. However, there are situations where an I²C slave is not able to co-operate with the clock speed given by the master and needs to slow down a little. This is done by a mechanism referred to as *clock stretching*.

An I²C slave is allowed to hold down the clock if it needs to reduce the bus speed. The CozIR®-Blink operates at up to 100kHz, and maximum stretch is never more than 500usecs.

Ultra-Low Power CO₂ Sensor

I²C REGISTER MAP SUMMARY

REGISTER	ADDRESS	DESCRIPTION	DEFAULT	RANGE	Size (bytes)	READ/WRITE
R2 (0x02)	00000010	CO ₂ Level (ppm)	N/A	0 – Full scale range of sensor	2	READ only
R5 (0x05)	00000101	Sensor Control Settings			1	WRITE only
R12 (0x0C)	00001100	Auto-Zero Target	400ppm	0 to full scale	2	READ/WRITE
R18 (0x12)	00010010	Target value for CO ₂ in fresh air (in ppm)	400ppm	0 to full scale	2	READ/WRITE
R20 (0x14)	00010100	Known CO ₂ Concentration (in ppm)		0 to full scale	2	READ/WRITE
R26 (0x1A)	00011010	Auto-Zero Cycles	5000	50 – 39268	2	READ/WRITE*
R38 (0x26)	00100110	Serial Number	N/A		4	READ only
R42 (0x2A)	00101010	nPulse (1-32)	4296	456 - 8392	2	READ/WRITE*
R78 (0x4E)	01001110	Auto-Zero Control	2		1	READ/WRITE*
R118 (0x76)	11101110	Altitude pressure in mbar	1013	697 – 1050	2	READ/WRITE

Notes

* indicates a sensor zero should be performed after the default values are changed.

Ultra-Low Power CO₂ Sensor

CO₂ LEVEL MEASUREMENT VALUE

REGISTER	ADDRESS	BIT	LABEL	DESCRIPTION	DEFAULT	READ/WRITE
R2 (0x02)	00000010	15:0		CO ₂ level, in ppm		Read only

The measured CO₂ level is read from Register R2, 2 bytes, MSB first. The value is CO₂ level in ppm.

ZERO SETTING CONTROL

REGISTER	ADDRESS	BIT	LABEL	DESCRIPTION	DEFAULT	READ/WRITE
R5 (0x05)	00000101	0	Air Zero	Sets the zero point in ambient air, default value is 400ppm CO ₂ . Write the required ambient CO ₂ level into Register 18 00000000: No Zero 00000001: Zero	00000000	Write
		2	X Zero	Sets the zero point with the sensor in a known concentration of CO ₂ . Write the target ppm concentration into Register 20. 00000000: No X Zero 00000100: X Zero	00000000	Write

ZERO IN FRESH AIR

REGISTER	ADDRESS	BIT	LABEL	DESCRIPTION	DEFAULT	READ/WRITE
R18 (0x12)	00010010	15:0		Target value for CO ₂ in fresh air	110010000	Read/Write

The target value for CO₂ in fresh air is stored in register 18. The default is 400ppm.

ZERO IN A KNOWN GAS CONCENTRATION

REGISTER	ADDRESS	BIT	LABEL	DESCRIPTION	DEFAULT	READ/WRITE
R20 (0x14)	00010100	15:0	X Zero	CO ₂ concentration (in ppm)		Read/Write

Stores the target ppm concentration of CO₂ gas. All CO₂ values are in ppm. CO₂ level is a two-byte value, MSB first.

Ultra-Low Power CO₂ Sensor

AUTO-ZERO CYCLES

REGISTER	ADDRESS	BIT	LABEL	DESCRIPTION	DEFAULT	READ/WRITE
R26 (0x1A)	00011010	15:0		Number of power cycles between auto-zero events	1001110001000	Read/Write*

SERIAL NUMBER

REGISTER	ADDRESS	BIT	LABEL	DESCRIPTION	DEFAULT	READ/WRITE
R38 (0x26)	00100110	31:0	SERIAL NUMBER	Unique sensor serial number, 32-digit code		Read only

nPULSE

REGISTER	ADDRESS	BIT	LABEL	DESCRIPTION	DEFAULT	READ/WRITE
R42 (0x2A)	00101010	15:0	nPulse	Sets the number of pulses per reading (1-32)	0001000011001000	Read/Write

The nPulse setting can be set from 1 pulse to 32 pulses using the value of $(npulse * 256) + 200$ in this register. For example, the default value is 16 pulses. The register value is $(16 * 256) + 200 = 4296$.

AUTO-ZERO CONTROL

REGISTER	ADDRESS	BIT	LABEL	DESCRIPTION	DEFAULT	READ/WRITE
R78 (0x4E)	01001110	7:0	AUTO CAL	Auto-calibration control 00000000 = Disabled 00000010 = Enabled	00000010	Read/Write

ALTITUDE COMPENSATION

REGISTER	ADDRESS	BIT	LABEL	DESCRIPTION	DEFAULT	READ/WRITE
R118 (0x76)	11101110	15:0	PRESSURE	Ambient Pressure (mbar)	1013	READ/WRITE

Ultra-Low Power CO₂ Sensor

CONNECTION DIAGRAM FOR I²C INTERFACE

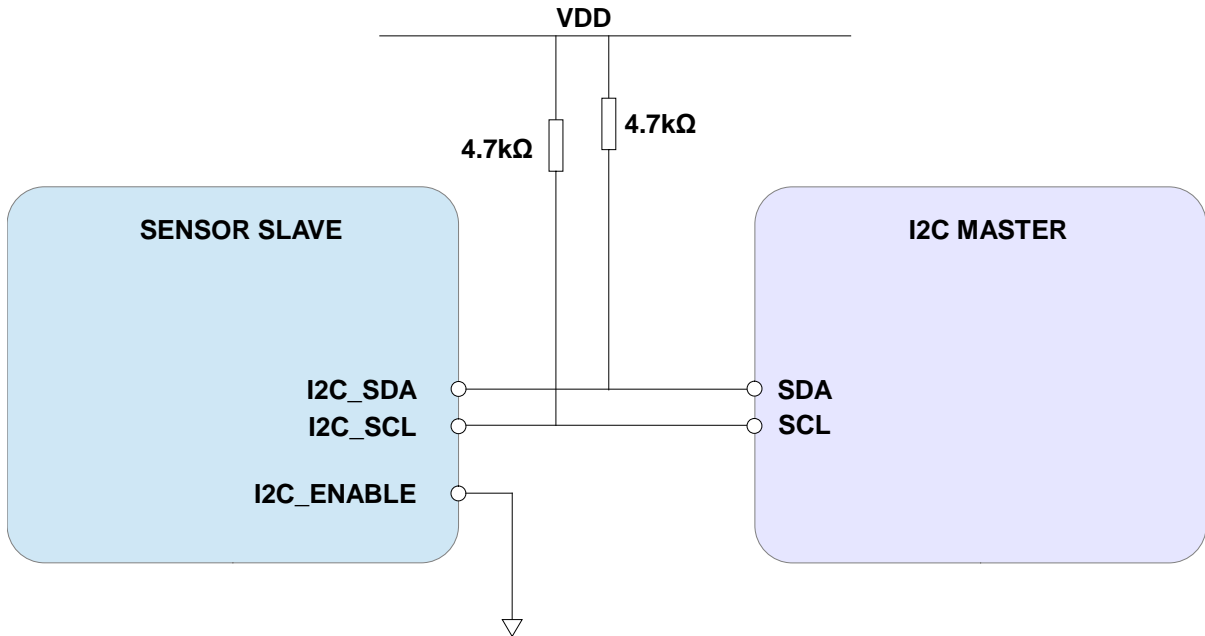

Ultra-Low Power CO₂ Sensor

UART INTERFACE MODE

Leaving the I2C_ENABLE pin floating puts the CozIR®-Blink into UART control interface mode. The status of the I2C_ENABLE is only sampled at power up.

The **Rx_In** and **Tx_Out** pins are normally high, suitable for direct connection to a UART. If the sensor is to be read by a true RS232 device (e.g., a PC), it is necessary to use a level converter to step up/down the voltage and invert the signal.

CONTROL INTERFACE TIMING - UART MODE

PARAMETER	SYMBOL	MIN	TYP	MAX	UNIT
Baud Rate			38,400		Bits/s
Data Bits		8			
Parity		None			
Stop Bits		1			
Hardware Flow Control		None			

UART COMMAND PROTOCOL

All UART commands must be terminated with a carriage return and line feed <CR><LF>, hex 0x0D 0x0A. In this document, this is shown as '\r\n'. UART commands that take a parameter always have a space between the letter and the parameter. The sensor will respond with a '?' if a command is not recognised. The two most common causes are missing spaces or missing <CR><LF> terminators.

All command communications are in ASCII and are terminated by carriage return, line feed (0x0D 0x0A). This document uses the protocol "\r\n" to indicate the carriage return line feed. All responses from the sensor, including measurements, have a leading space (ASCII character 32).

The character '#' represents an ASCII representation of a numeric character (0-9). Note there is a space between the first letter and any parameter. For example, the X command reads "X space 2000 carriage return line feed".

UART OPERATION

When powered up and after the READY pin has been pulsed high (indicating the measurement is complete), the sensor is pre-programmed to automatically transmit a CO₂ reading if it receives any character.

The CO₂ reading will be in 2 bytes, MSB first, then LSB followed by a status byte.

Note that the default data output format is Binary.

After the initial measurement, the sensor will cease to transmit another CO₂ reading until it has been power cycled.

Ultra-Low Power CO₂ Sensor

UART INTERFACE SUMMARY

Command	Use	Example	Response	Comments
A ###\r\n	Set value of nPulse	A 16\r\n	A 00016\r\n	See "nPulse"
a\r\n	Return the value of nPulse	a\r\n	a 00016\r\n	See "nPulse"
G\r\n	Zero-point calibration using fresh air.	G\r\n	G 33000\r\n	See "Zero Point Setting"
P 8 ###\r\n P 9 ###\r\n	Sets value of CO ₂ background concentration in ppm for auto-zero	P 8 1\r\n P 9 144\r\n	P 00008 00001\r\n P 00009 00144\r\n	Two-byte value P 8 = MSB P 9 = LSB 400ppm in the example
P 10 ###\r\n P 11 ###\r\n	Sets value of CO ₂ background concentration in ppm used for zero-point setting in fresh air.	P 10 1\r\n P 11 144\r\n	P 00010 00001\r\n P 00011 00144\r\n	Two-byte value P 10 = MSB P 11 = LSB 400ppm in the example
U\r\n	Zero-point setting using nitrogen.	U\r\n	U 33000\r\n	See "Zero Point Setting"
u #####\r\n	Manual setting of the zero point.	u 32997\r\n	u 32997\r\n	See "Zero Point Setting"
X #####\r\n	Zero-point setting using a known gas concentration	X 2000\r\n	X 32997\r\n	See "Zero Point Setting"
Y\r\n	Return firmware version and sensor serial number	Y\r\n	Returns <u>two</u> lines	
Z	Return the most recent CO ₂ measurement.	Z	0000010111110001	1521ppm in the example
@ #####\r\n	Sets power cycle auto-zero count	@ 5000\r\n	@ 05000\r\n	See "Auto-Zero Function" for details
.\r\n	Return the multiplier required to convert the Z output to ppm	.\r\n	. 00001\r\n	Multiply by 1 in the example
*\r\n	Return configuration information.	*\r\n		
[#####\r\n	Set pressure value in mbar	[997\r\n	[00997\r\n	See "Altitude Pressure Compensation"
] #####\r\n	Read pressure value in mbar]\r\n] 00997\r\n	See "Altitude Pressure Compensation"

Ultra-Low Power CO₂ Sensor

CO₂ LEVEL MEASUREMENT VALUE - Z INFORMATION (0x5A)

Description	Reports the latest CO ₂ measurement in response to any character
Syntax	ASCII Character 'Z'
Example	Z

The CozIR-Blink is pre-programmed to minimise power consumption. After power up, the CozIR®-Blink will always respond initially with a CO₂ reading, regardless of what command is sent. For the initial CO₂ reading, the UART command does **NOT** need to be terminated with a carriage return and line feed <CR><LF>.

The sensor will return the CO₂ reading on receiving any UART command (such as Z). The CO₂ reading will be a binary number, sent as 2 bytes, MSB first, then the LSB followed by a status byte.

The status byte is a basic sensor health check.

0x55 (binary 0101 0101) indicates sensor checks passed.

0xAA (binary 1010 1010) indicates sensor checks failed.

For example, if the sensor reading is 1521ppm, the sensor will respond as follows: -

Byte 1: 00000101 (0x05)

Byte 2: 11110001 (0xF1)

Byte 3: 01010101 (0x55)

If the user sends a UART command followed by a carriage return and line feed <CR><LF>, the sensor will transmit a further 3 bytes of data after the CO₂ reading and status byte. These can be safely ignored.

After the initial CO₂ reading has been sent by the sensor, all subsequent UART commands must be terminated with a carriage return and line feed <CR><LF>.

After reading the CO₂ value, the sensor should be powered down unless the sensor settings need to be modified.

Ultra-Low Power CO₂ Sensor

CO₂ MEASUREMENT Z SCALING FACTOR – UART MODE

To calculate the measurement value in ppm, the 'Z' value must be converted into ppm by using the '.' multiplier factor. The multiplier will depend on the full-scale measurement range of the sensor.

Measurement Range of Sensor	CO ₂ Measurement Scaling Factor (Z)	CO ₂ Measurement Output Units	Example
0 – 1%	1	ppm	Z 00631 = 631ppm

'.' COMMAND (0x2E)

Description	Returns a number indicating what multiplier must be applied to the Z CO ₂ measurement output to convert it into ppm.
Syntax	ASCII character '.', terminated by 0x0D 0x0A (CR & LF)
Example	.\r\n
Response	. 00001\r\n (this number is always 1 for CozIR®-Blink)

nPULSE SETTING – UART MODE

UART Command	Use	Default	Range	Example	Response	Comments
A ###\r\n	Set <i>npulse</i> , the number of pulses	16	1 - 32	A 16\r\n	A 00016\r\n	Lower npulse reduces power consumption.
a\r\n	Return <i>npulse</i> value	16	1 - 32	a\r\n	a 00016\r\n	

A COMMAND (0x41)

Description	Set the value for the number of pulses
Syntax	ASCII character 'A', SPACE, decimal, terminated by 0x0D 0x0A (CR & LF)
Example	A 16\r\n
Response	A 00016\r\n (this number is variable)

a COMMAND (0x61)

Description	Return the value for the number of pulses
Syntax	ASCII Character 'a' terminated by 0x0D 0x0A (CR & LF)
Example	a\r\n
Response	a 00016\r\n (this number is variable)

Ultra-Low Power CO₂ Sensor

ZERO POINT SETTING COMMANDS – UART MODE

Command	Use	Default	Range	Example	Response	Comments
G\r\n	Zero-point setting using fresh air			G\r\n	G 33000\r\n	See “Zero Point Setting”
U\r\n	Zero-point setting using nitrogen			U\r\n	U 33000\r\n	See “Zero Point Setting”
u #####\r\n	Manual setting of the zero point			u 32997\r\n	u 32997\r\n	See “Zero Point Setting”
X #####\r\n	Zero-point setting using a known gas concentration			X 2000\r\n	X 32997\r\n	See “Zero Point Setting”
P 8 ###\r\n P 9 #\r\n	Sets value of CO ₂ background concentration in ppm for auto-zero	P 8 1\r\n P 9 144\r\n		Two-byte value P 8 = MSB P 9 = LSB 400ppm in the example	P 00008 #####\r\n P 00009 #####\r\n	
P 10 ###\r\n P 11 #\r\n	Sets value of CO ₂ background concentration in ppm used for zero-point setting in fresh air.	P 10 1\r\n P 11 144\r\n		Two-byte value P 10 = MSB P 11 = LSB 400ppm in the example	P 00010 #####\r\n P 00011 #####\r\n	

Ultra-Low Power CO₂ Sensor

G COMMAND (0x47)

Description	Sets the zero point assuming the sensor is in fresh air (typically 400ppm CO ₂ , but level can be set by user – see P commands.)
Syntax	ASCII character 'G'
Example	G\r\n
Response	G 33000\r\n (the number is variable)

U COMMAND (0x55)

Description	Sets the zero point assuming the sensor is in 0ppm CO ₂ such as nitrogen
Syntax	ASCII Character 'U' terminated by 0x0D 0x0A (CR & LF)
Example	U\r\n
Response	U 32767\r\n (the number is variable)

u COMMAND (0x75)

Description	Forces a specific zero set point value. Value in ppm.
Syntax	ASCII character 'u', SPACE, decimal, terminated by 0x0D 0x0A (CR & LF)
Example	u 32767\r\n
Response	u 32767\r\n

X COMMAND (0x58)

Description	Sets the zero point with the sensor in a known concentration of CO ₂ . Value in ppm
Syntax	ASCII character 'X' then a space, then the gas concentration.
Example	X 1000\r\n
Response	X 33000\r\n (the number is variable)

Ultra-Low Power CO₂ Sensor

P COMMAND - CO₂ Level for Auto-Zero

Description	Sets the value of CO ₂ in ppm used for auto-zero
Syntax	ASCII character 'P' then a space, then 8, then a space, then MSB terminated by 0x0D 0x0A (CR & LF) ASCII character 'P' then a space, then 9, then a space, then LSB terminated by 0x0D 0x0A (CR & LF)
Example	P 8 1\r\n P 9 144\r\n
Response	P 00008 00001\r\n P 00009 00144\r\n

The value is entered as a two-byte word, MSB first.

MSB = Integer (Concentration/256)

LSB = Concentration – (256*MSB)

In the above example, target CO₂ background concentration is 400ppm.

MSB = Integer (400/256) = 1

LSB = 400 – 256 = 144

P COMMAND – CO₂ Level for Zero-Point Setting

Description	Sets value of CO ₂ in ppm for zero-point setting in fresh air.
Syntax	ASCII character 'P' then a space, then 10, then a space, then MSB terminated by 0x0D 0x0A (CR & LF) ASCII character 'P' then a space, then 11, then a space, then LSB terminated by 0x0D 0x0A (CR & LF)
Example	P 10 7\r\n P 11 208\r\n
Response	P 00010 00007\r\n P 00011 00208\r\n

MSB = Integer (Concentration/256)

LSB = Concentration – (256*MSB)

In the above example, target zero-point CO₂ concentration is 2000ppm.

MSB = Integer (2000/256) = 7

LSB = 2000 – (256*MSB) = 208

Ultra-Low Power CO₂ Sensor

ALTITUDE PRESSURE COMPENSATION

UART Command	Use	Default	Range	Example	Response	Comments
[#####\r\n	Sets the pressure value (mbar)	1013	0-65536	[990\r\n	[00990\r\n	See “Altitude Pressure Compensation”
]\r\n	Returns the pressure value mbar] 990\r\n] 00990\r\n	See “Altitude Pressure Compensation”

[COMMAND (0x5B)

Description	Set the altitude pressure value in mbar
Syntax	ASCII character '[', SPACE, decimal, terminated by 0x0D 0x0A (CR & LF)
Example	[990\r\n
Response	[00990\r\n (the number mirrors the input value)

] COMMAND (0x5D)

Description	Reads the altitude pressure value in mbar
Syntax	ASCII character ']', SPACE, decimal, terminated by 0x0D 0x0A (CR & LF)
Example]\r\n
Response] 00990\r\n

Ultra-Low Power CO₂ Sensor

AUTO-ZERO INTERVAL – UART MODE

UART Command	Use	Default	Range	Example	Response	Comments
@ #####\r\n	Auto-zero interval setting, # power cycles			@ 5760\r\n	@ 05760\r\n	See “Auto-Zero Settings”

@ COMMAND (0x40)

Description	Sets the number of power cycles between auto-zero events.
Syntax	ASCII character '@' then a space, then the number of power cycles, terminated by 0x0D 0x0A (CR & LF)
Example	@ 5760\r\n
Response	@ 05760\r\n (this number is variable)

In the above example, if the sensor is powered up once every 2 minutes, and auto-calibration is once every 8 days, the power cycle auto-calibration counter should be set to 5760.

To read the auto-zeroing counter, send @\r\n. The sensor will respond with @ #####\r\n.

To disable auto-zeroing, send @ 0\r\n.

SERIAL NUMBER AND FIRMWARE VERSION – UART MODE

UART Command	Use	Default	Range	Example	Response	Comments
Y\r\n	Return firmware version and sensor serial number			Y\r\n	Returns <u>two</u> lines	

Ultra-Low Power CO₂ Sensor

Y COMMAND (0x59)

Description	The present version string for the firmware and serial number of the sensor.
Syntax	ASCII character 'Y', terminated by 0x0d 0x0a (CR & LF)
Example	Y\r\n
Response	Y, Aug 25 2021, 14:19:56, LP15132 B 528148 00000 Where; Aug 25 2021, 14:19:56 is the firmware compile date and time LP15132 is the firmware revision 528148 is the sensor ID

N.B. This command returns two lines split by a carriage return line feed and terminated by a carriage return line feed. This command requires that the sensor has been stopped (see 'K' command).

Ultra-Low Power CO₂ Sensor

CONNECTION DIAGRAM FOR UART INTERFACE

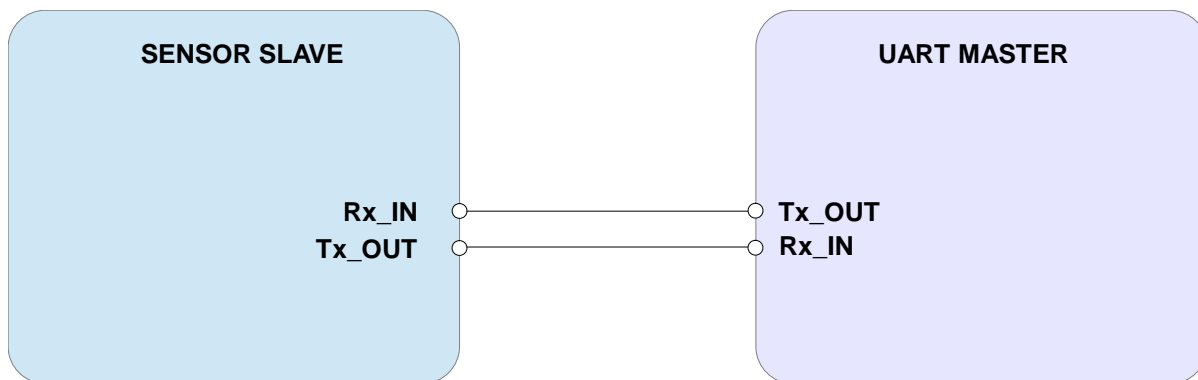



CozIR[®]-Blink

Ultra-Low Power CO₂ Sensor

IMPORTANT NOTICE

Gas Sensing Solutions Ltd. (GSS) products and services are sold subject to GSS's terms and conditions of sale, delivery and payment supplied at the time of order acknowledgement. GSS warrants performance of its products to the specifications in effect at the date of shipment. GSS reserves the right to make changes to its products and specifications or to discontinue any product or service without notice.

Customers should therefore obtain the latest version of relevant information from GSS to verify that the information is current. Testing and other quality control techniques are utilised to the extent GSS deems necessary to support its warranty. Specific testing of all parameters of each device is not necessarily performed unless required by law or regulation. In order to minimise risks associated with customer applications, the customer must use adequate design and operating safeguards to minimise inherent or procedural hazards. GSS is not liable for applications assistance or customer product design. The customer is solely responsible for its selection and use of GSS products. GSS is not liable for such selection or use nor for use of any circuitry other than circuitry entirely embodied in a GSS product.

GSS products are not intended for use in life support systems, appliances, nuclear systems or systems where malfunction can reasonably be expected to result in personal injury, death or severe property or environmental damage. Any use of products by the customer for such purposes is at the customer's own risk.

GSS does not grant any licence (express or implied) under any patent right, copyright, mask work right or other intellectual property right of GSS covering or relating to any combination, machine, or process in which its products or services might be or are used. Any provision or publication of any third party's products or services does not constitute GSS's approval, licence, warranty or endorsement thereof. Any third-party trademarks contained in this document belong to the respective third-party owner.

Reproduction of information from GSS datasheets is permissible only if reproduction is without alteration and is accompanied by all associated copyright, proprietary and other notices (including this notice) and conditions. GSS is not liable for any unauthorised alteration of such information or for any reliance placed thereon.

Any representations made, warranties given, and/or liabilities accepted by any person which differ from those contained in this datasheet or in GSS's standard terms and conditions of sale, delivery and payment are made, given and/or accepted at that person's own risk. GSS is not liable for any such representations, warranties or liabilities or for any reliance placed thereon by any person.

ADDRESS

Gas Sensing Solutions Ltd.
Grayshill Road
Cumbernauld
G68 9HQ
United Kingdom